



powering **marine** safety

BUKH H410

BUKH SOLAS MARINE DIESEL ENGINE H10 SERIES - 410 HP (302 KW)

This modern, electronically controlled design delivers 410PS and 174kg-m of torque from the powerful 10 liter in-line 6 cylinder engine.

The broad flat torque curve proves world-class diesel development and beats performance of competition models.

State-of-the-art fuel management system featuring Electronic Unit Injectors (EUI). The electronic engine control system makes the engine lighter, more quiet and fuel efficient with excellent compact dimensions.

The unique one-piece CGI (Compacted Graphite Iron) cylinder head makes the engine lighter and quieter than conventional heads for more comfort onboard.

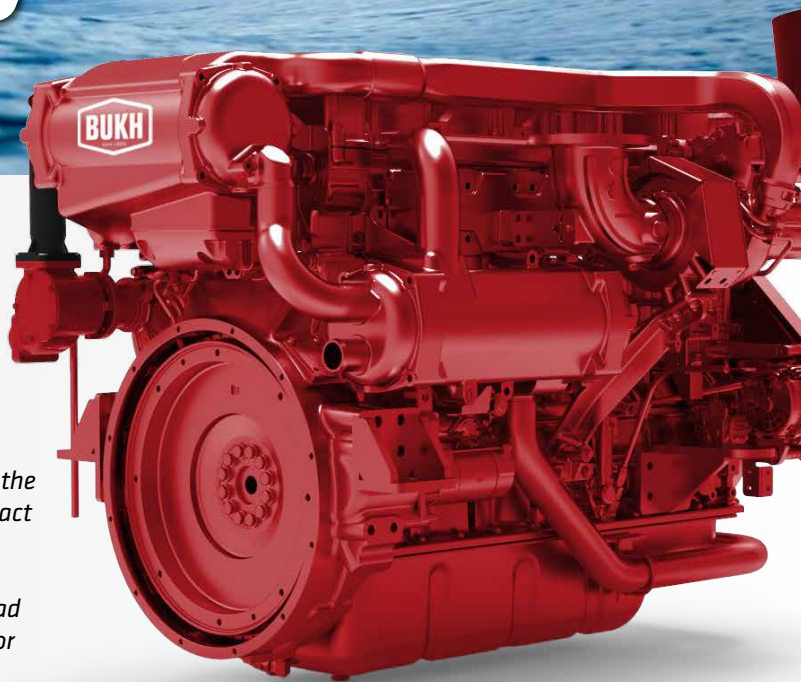

TECHNICAL DESCRIPTION:

ENGINE

- 6 cylinder in-line, 24 valve OHC
- Compacted Graphite Iron (CGI) cylinder head
- Cast iron cylinder block
- Gallery oil-cooled long lasting mono steel pistons
- Integrated water jacket
- Single serpentine belt system
- Drive belt auto tensioner

AIR INLET SYSTEM

- Reusable air filter
- Intake extension kit (Optional)

FUEL SYSTEM

- Electronic Unit Injector (EUI)
- Gear-driven fuel pump
- Electronically controlled injection timing
- Fine fuel filter and water separator

ENGINE MOUNTING

- Adjustable engine mounts (Optional)

ELECTRICAL SYSTEM

- 24 volt - 70A alternator
- Auxiliary engine stop button
- Air heating system for a trouble-free cold start
- NMEA2000 converter (Optional)
- 2 pole system (Optional)

COOLING SYSTEM

- Gear-driven seawater pump
- Seawater-cooled intercooler, heat exchanger
- Auxiliary connection for cabin heating
- Corrosion resistant material for seawater circuit
- Easily accessible rear mounted seawater impeller pump

LUBRICATION SYSTEM

- Easily exchangeable oil filter cartridge
- Integrated oil-cooler in cylinder block
- Closed system with forced feeding
- Eco type oil filter
- Electric oil extraction pump
- Gear-driven engine oil pump
- Washable auxiliary cyclone oil filter

EXHAUST SYSTEM

- Engine coolant cooled exhaust manifold
- Cast iron exhaust elbow
- E-VGT (Electric Variable Geometry Turbocharger)

INSTRUMENT BOX ASSEMBLY

- Engine self-protection and diagnosis
- Displays CAN information
- Displays engine diagnostic error codes
- Audible alarm and control lamps
- Idle & PTO rpm adjustable switch

EMISSIONS

- IMO Tier II
- EPA Tier III
- RCD II

TYPE APPROVAL OPTIONS

- EIAPP
- RINA (Ship)

As BUKH is always endeavouring to improve the engines, specifications mentioned are subject to alterations without previous notice.

BUKH H410

BUKH SOLAS MARINE DIESEL ENGINE

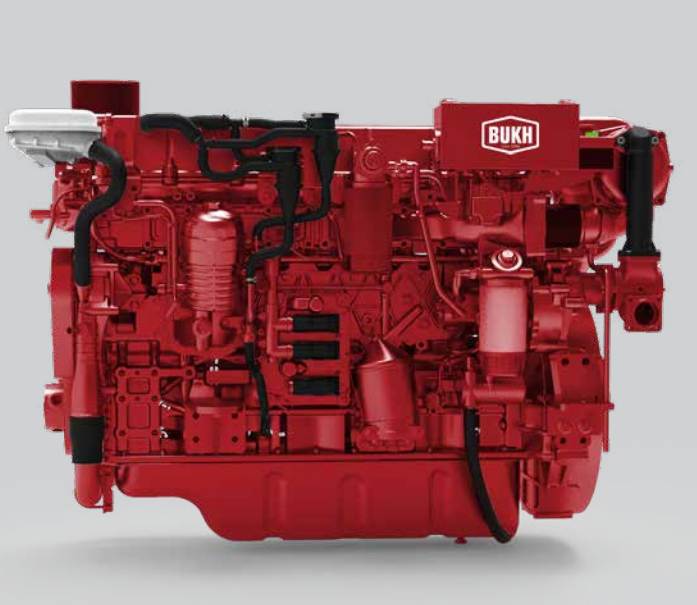

Specifications H410

Propulsion System	Shaftdrive
Engine Duty Rating	Heavy Duty (S1)
Configuration	4-stroke, 24-valve DOHC, E-VGT with intercooler, water cooling
Output [PS (kW)]	410 (302)
Rated RPM	2,000
Cylinders	In-line 6
Displacement [cc]	9,960
Bore X Stroke [mm]	122 X 142
Compression Ratio	16.0 : 1
Max. Torque	174 kg·m @ 1,100 rpm
Injection System	Electronic Unit Injector (EUI)
Alternator	24V-70A
Engine Diagnosis	YES
Max Fuel Consumption [l/h]	81,8
Dry Weight [kg]	1,120
Flywheel	SAE 14
Flywheel Housing	SAE 1

mygind-co.dk

Dimensions H410 (Not for installation)

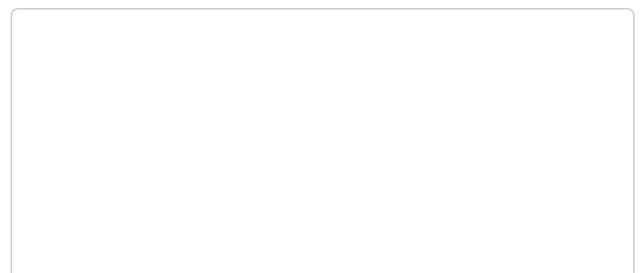
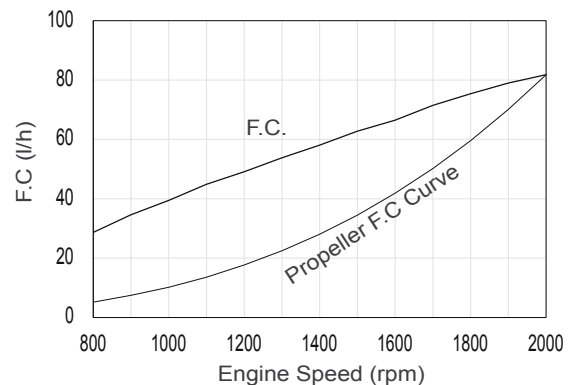
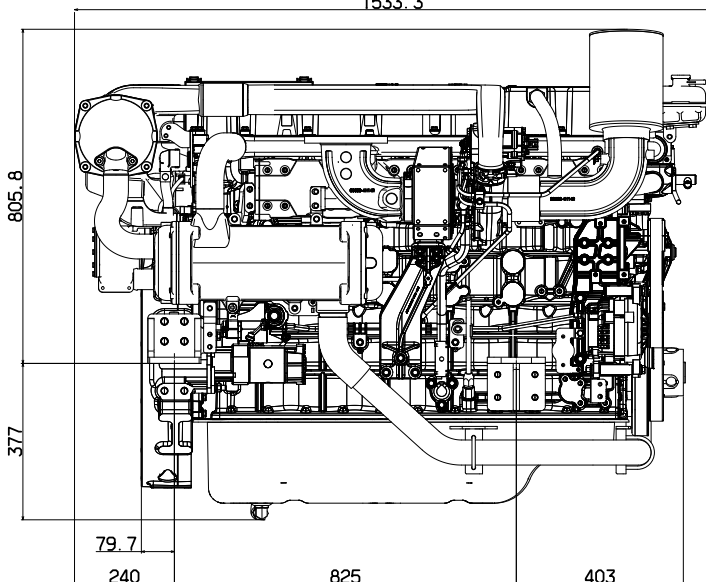
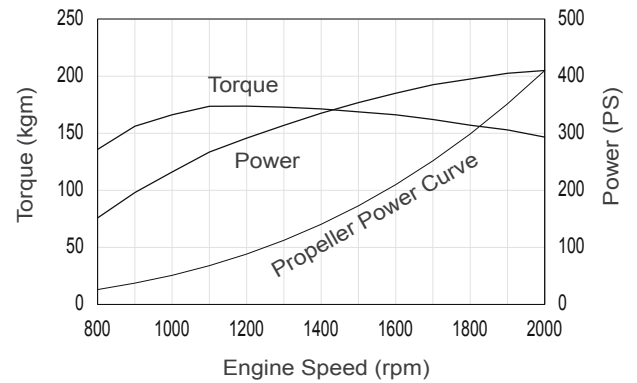
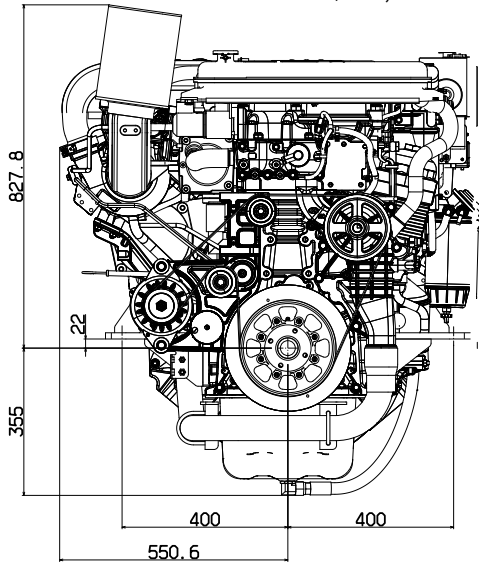

SOLAS approved by Det Norske Veritas
Notified Body: No. 0575