



powering **marine** safety

# BUKH H345

## BUKH SOLAS MARINE DIESEL ENGINE H10 SERIES - 345 HP (253,8 KW)

*This modern, electronically controlled design delivers 345 PS and 152 kg·m of torque from the powerful 10 liter in-line 6 cylinder engine.*

*The broad flat torque curve proves world-class diesel development and beats performance of competition models.*

*State-of-the-art fuel management system featuring Electronic Unit Injectors (EUI). The electronic engine control system makes the engine lighter, more quiet and fuel efficient with excellent compact dimensions.*

*The unique one-piece CGI (Compacted Graphite Iron) cylinder head makes the engine lighter and quieter than conventional heads for more comfort onboard.*

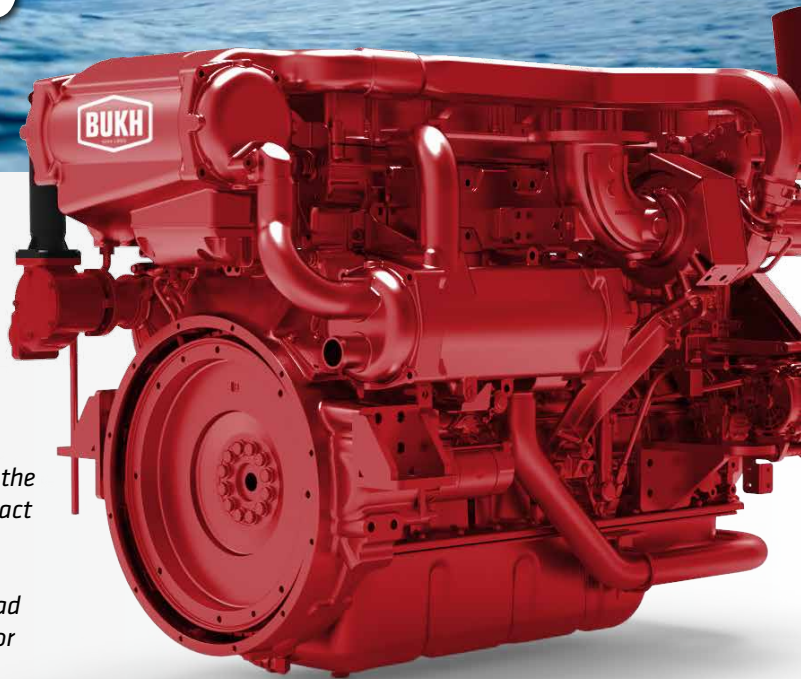

### TECHNICAL DESCRIPTION:

#### ENGINE

- 6 cylinder in-line, 24 valve OHC
- Compacted Graphite Iron (CGI) cylinder head
- Cast iron cylinder block
- Gallery oil-cooled long lasting mono steel pistons
- Integrated water jacket
- Single serpentine belt system
- Drive belt auto tensioner

#### AIR INLET SYSTEM

- Reusable air filter
- Intake extension kit (Optional)

#### FUEL SYSTEM

- Electronic Unit Injector (EUI)
- Gear-driven fuel pump
- Electronically controlled injection timing
- Fine fuel filter and water separator

#### ENGINE MOUNTING

- Adjustable engine mounts (Optional)

#### ELECTRICAL SYSTEM

- 24 volt - 70A alternator
- Auxiliary engine stop button
- Air heating system for a trouble-free cold start
- NMEA2000 converter (Optional)
- 2 pole system (Optional)

#### COOLING SYSTEM

- Gear-driven seawater pump
- Seawater-cooled intercooler, heat exchanger
- Auxiliary connection for cabin heating
- Corrosion resistant material for seawater circuit
- Easily accessible rear mounted seawater impeller pump

#### LUBRICATION SYSTEM

- Easily exchangeable oil filter cartridge
- Integrated oil-cooler in cylinder block
- Closed system with forced feeding
- Eco type oil filter
- Electric oil extraction pump
- Gear-driven engine oil pump
- Washable auxiliary cyclone oil filter

#### EXHAUST SYSTEM

- Engine coolant cooled exhaust manifold
- Cast iron exhaust elbow
- E-VGT (Electric Variable Geometry Turbocharger)

#### INSTRUMENT BOX ASSEMBLY

- Engine self-protection and diagnosis
- Displays CAN information
- Displays engine diagnostic error codes
- Audible alarm and control lamps
- Idle & PTO rpm adjustable switch

#### EMISSIONS

- IMO Tier II
- EPA Tier III
- RCD II

#### TYPE APPROVAL OPTIONS

- EIAPP

As BUKH is always endeavouring to improve the engines, specifications mentioned are subject to alterations without previous notice.

# BUKH H345

## BUKH SOLAS MARINE DIESEL ENGINE

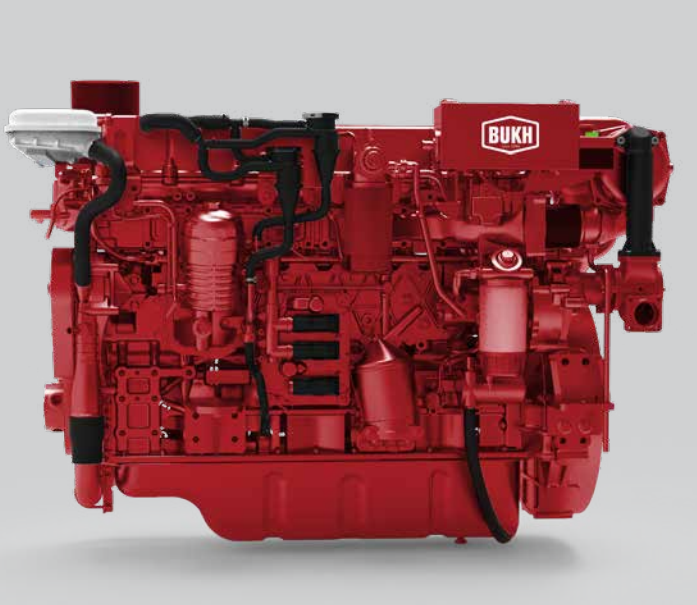

### Specifications H345

Propulsion System	Shaftdrive
Engine Duty Rating	Heavy Duty (S1)
Configuration	4-stroke, 24-valve DOHC, E-VGT with intercooler, water cooling
Output [PS (kW)]	345 (253.8)
Rated RPM	1,800
Cylinders	In-line 6
Displacement [cc]	9,960
Bore X Stroke [mm]	122 X 142
Compression Ratio	16.0 : 1
Max. Torque	152 kg·m @ 1,100 rpm
Injection System	Electronic Unit Injector (EUI)
Alternator	24V-70A
Engine Diagnosis	YES
Max Fuel Consumption [l/h]	66.8
Dry Weight [kg]	1,120
Flywheel	SAE 14
Flywheel Housing	SAE 1

### Dimensions H345 (Not for installation)

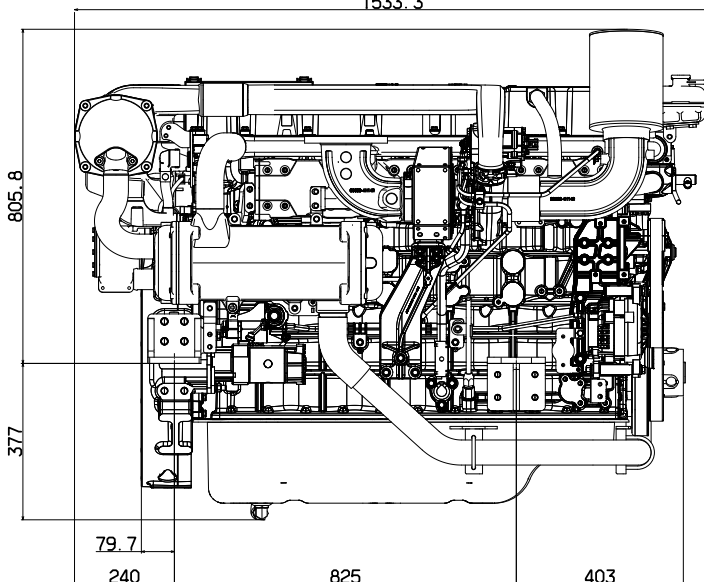
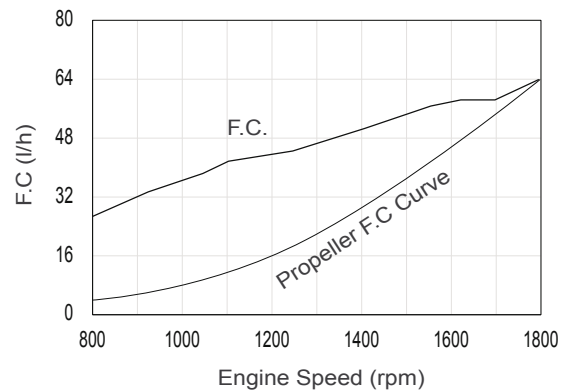
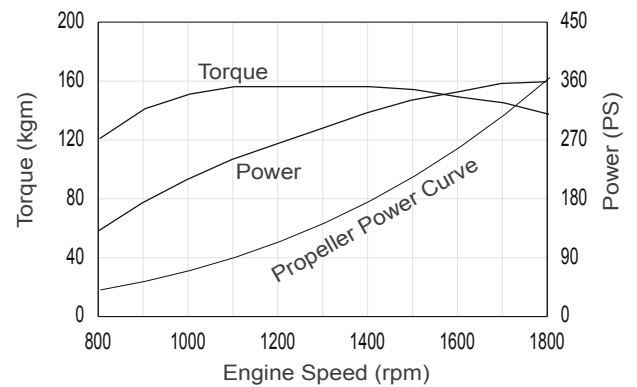
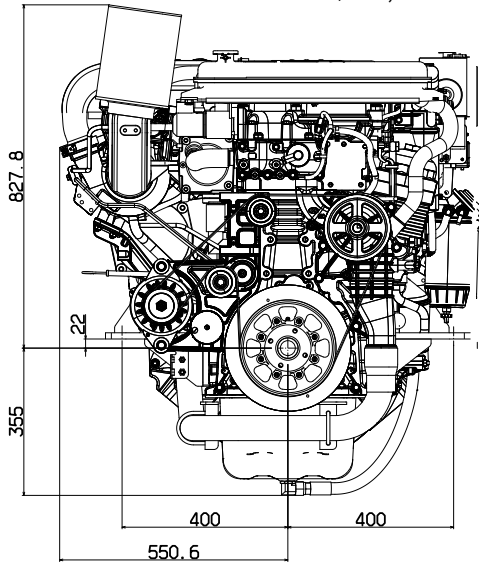

SOLAS approved by Det Norske Veritas  
Notified Body: No. 0575